

REVISION HISTORY			
REV	DESCRIPTION	DATE	APPROVED
A	ORIGINAL RELEASE	4-2452014	

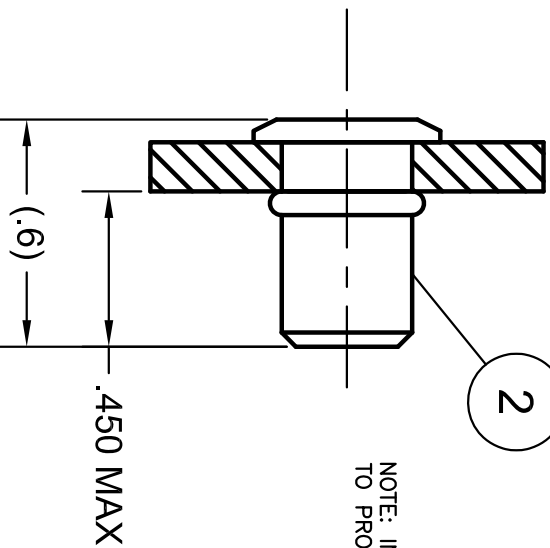
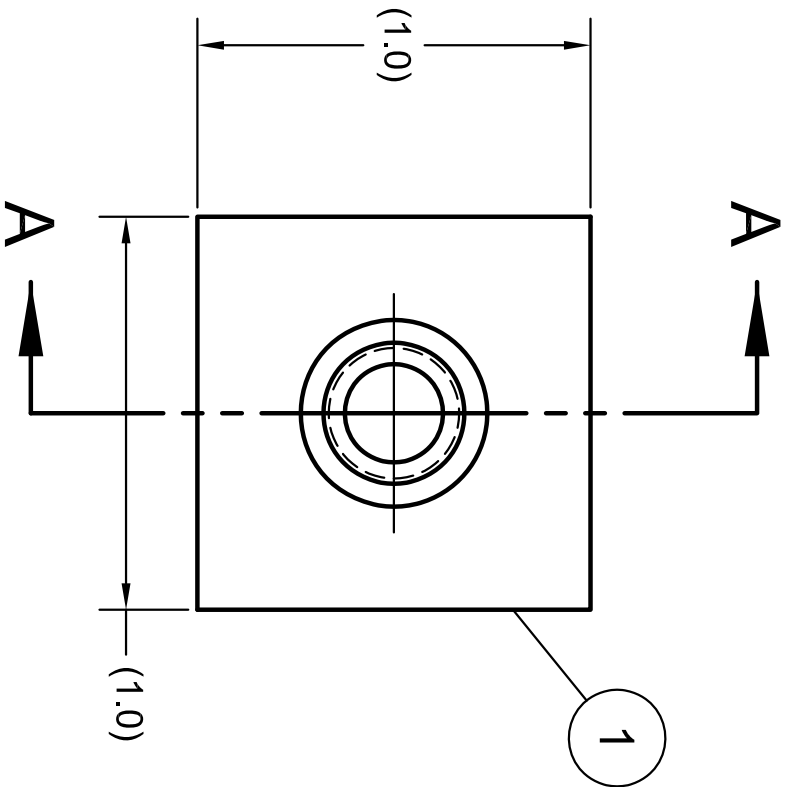

SECTION A-A

ITEM	PART NO.	DESCRIPTION	QTY
2	TX-008	RIVNUT, .250-20 FOR .125	1
1	TX-001	MOUNT, PANEL	1

UNIVERSITY OF MEMPHIS
DEPARTMENT OF ENGINEERING TECHNOLOGY

ASSEMBLY, MOUNT, PANEL
TX MODEL EXTRUDER

SIZE	DATE	DWG NO	REV
A	4-25-2014	TX-003	A

SCALE: 2:1 DRAWN BY: R.H.

UNLESS OTHERWISE SPECIFIED:
ALL DIMENSIONS ARE INCHES

UNSPECIFIED TOLERANCES	
LENGTH	SURFACE FINISH
.0 = ±.1	RMS 140
.00 = ±.01	μin
.000 = ±.005	ANGULAR ±.25°
.0000 = ±.005	

THIRD ANGLE

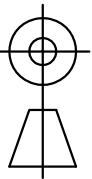

DIMENSIONING & TOLERANCING IN
ACCORDANCE WITH
ANSI/ASME Y14.5M - 1994

THIS DRAWING AND/OR SPECIFICATION CONTAINS
INFORMATION THAT IS NOT CONFIDENTIAL TO THE
UNIVERSITY OF MEMPHIS. BY RETENTION, THE
RECIPIENT AGREES TO REPRODUCE OR COPY IT IN
PART AND IN WHOLE WITHOUT WRITTEN PERMISSION,
AND TO MAKE ANY USE OF IT AS SEEMS FITTING.